

Distributed by  
**Raymarine**

Any reference to Raytheon or RTN in this manual should be interpreted as Raymarine. The names Raytheon and RTN are owned by the Raytheon Company.

Return to  
Winston

**Apelco**

Raytheon

**510**

Instruction Manual

## PURPOSE

This manual contains very important information on the installation, operation, and maintenance of your new equipment. To get the best results in operation and performance, please take the time to read this manual thoroughly.

### IMPORTANT NOTICE

*This device is only an aid to navigation. its accuracy can be affected by many factors including equipment failure or defects, environmental conditions, and improper handling or use. It is the user's responsibility to exercise common prudence and navigational judgment, and this device should not be relied upon as a substitute for such prudence and judgment.*

APELCO MARINE ELECTRONICS products are supported by a network of Authorized Service Representatives. For product information you may contact the following regional centers:

#### UNITED STATES.....

Apelco Marine Electronics Company  
676 Island Pond Road  
Manchester N.H. 03109-5420  
Telephone: (603) 647-7530

#### EUROPE.....

Raytheon Marine Europe  
Anchorage Park  
Portsmouth  
Hampshire PO# 5TD  
England  
Telephone: 44- (01) 705 693611

### NOTE

This device complies with part 15 of the FCC Rules. Operation is subject to the conditions that this device does not cause harmful interference.

# TABLE OF CONTENTS

		Page
<b>SECTION 1</b>	<b>GENERAL DESCRIPTION</b>	
1.1	INTRODUCTION.....	1
1.2	EQUIPMENT FEATURES.....	1
<b>SECTION 2</b>	<b>INSTALLATION</b>	
2.1	UNPACKING AND INSPECTION .....	2
2.2	EQUIPMENT SUPPLIED .....	2
2.2.1	Optional Accessories .....	2
2.3	ELECTRICAL CONNECTIONS.....	3
2.3.1	Assembly .....	3
<b>SECTION 3</b>	<b>OPERATIONS</b>	
3.1	INTRODUCTION.....	7
3.2	CONTROLS AND LCD DISPLAY .....	7
3.2.1	Controls.....	7
3.2.2	LCD Display .....	11
3.3	OPERATING PROCEDURES.....	12
3.3.1	Tuning the Power On.....	12
3.3.2	The 16 PLUS (priority) channel.....	13
3.3.3	Channel Memory.....	14
3.3.4	Master Reset.....	14
3.3.5	Scan Mode.....	14
3.3.6	Seek Mode.....	15
3.3.7	Monitor Mode .....	15
3.3.8	VHF510 Marine Channels & Their Usage.....	16
<b>SECTION 4</b>	<b>TECHNICAL DESCRIPTION</b>	
4.1	GENERAL .....	19
4.2	THE CONTROL SECTION.....	19
4.3	THE TRANSMITTER/RECEIVER/PLL SECTIONS .....	19
4.3.1	PLL Circuit .....	19
4.3.2	Trasmitter Circuit.....	20
4.3.3	Receiver Circuit.....	20
4.4	SPECIFICATIONS .....	23
<b>SECTION 5</b>	<b>MAINTENANCE/ALIGNMENTS/TROUBLESHOOTING</b>	
5.1	GENERAL .....	25
5.1.1	Product Support and Customer Service .....	25
5.2	PREVENTIVE MAINTENANCE .....	25
5.3	ALIGNMENTS AND SERVICE.....	26
5.3.1	PLL Adjustment.....	27
5.3.2	Frequency Adjustment .....	27
5.3.3	Modulation Adjustment .....	28
5.3.4	Power Output Adjustment .....	29
5.3.5	RF Sensitivity Adjustment .....	29
5.3.6	Weather Alert Frequency Adjustment.....	30
5.4	TROUBLESHOOTING GUIDE.....	31

**SECTION 6**

**PARTS LIST AND DRAWINGS**

6.1	PARTS LOCATION LIST .....	34
6.2	ASSEMBLY DRAWING.....	42
6.3	SCHEMATIC DIAGRAMS/PC BOARDS.....	44
6.4	INTERNAL WIRING DIAGRAM .....	52

**SECTION 7**

**APPENDIX**

7.1	VHF MARINE CHANNEL USAGE GUIDE.....	53
-----	-------------------------------------	----

## GLOSSARY OF TERMS

VHF .....	Very High Frequency (30 MHz to 300 MHz)
FM .....	Frequency Modulation.
MODULATION .....	To vary a carrier wave.
CARRIER WAVE .....	A radio frequency on which intelligence is superimposed.
DUAL WATCH .....	Monitors channel 16 while working on another channel.
U.S.A. CHANNELS .....	Channel designations as defined by the FCC.
INTERNATIONAL CHANNELS .....	Channel designations as defined by the International Telecommunication Union.
CANADIAN CHANNELS .....	Channel designations as defined by the ISC.
WEATHER CHANNELS .....	Channels for routine and emergency weather information broadcast by NOAA.
SIMPLEX .....	Transmit and receive on the same frequency.
DUPLEX .....	Transmit and receive on different frequencies.
SQUELCH .....	To suppress totally.
LCD .....	Liquid crystal display.
TX .....	Transmit.
RX .....	Receive.
RF .....	Radio Frequency.
CPU .....	Control Processor Unit.
PLL .....	Phase Lock Loop (A type of Frequency Synthesizer).
VCO .....	Voltage Controlled Oscillator.
PTT .....	Microphone push-to-talk switch.

---

# SECTION 1

---

## GENERAL DESCRIPTION

### 1.1 INTRODUCTION

Congratulations on your purchase of Apelco's VHF510 handheld marine radiotelephone.

The VHF 510 is a CPU-controlled, digitally synthesized, compact handheld transceiver, which provides reliable simplex and duplex (two-frequency) communications between ships and from ships at sea to public or private shore stations. The VHF 510 provides two-way communications on the International and U.S. channels, reception on 10 separate weather channels, and two-way communications on the international calling and safety channel (16).

This manual describes the physical and functional characteristics of the radiotelephone.

### 1.2 EQUIPMENT FEATURES

The VHF 510 is designed and manufactured to provide ease of operation with excellent reliability. The important built-in features of the equipment are listed below:

- Waterproof to U.S.C.G. standard CFR-46.
- All solid-state circuitry for low current drain and maximum reliability.
- Series diode protection on input power circuits to prevent reverse polarity damage.
- High-performance receiver section with optimum selectivity.
- 53 channel transmit and 93 channel receive capability within the assigned VHF-FM maritime band. All US and International channels are included.
- Exclusive circuit that automatically selects 16 PLUS (priority) channel when the radio is turned on.
- Exclusive weather alert feature (when in Monitor Mode).
- Up to 10 memory channels available for scan and seek operations.
- Selected channel number indicated on the LCD digital display.
- Aluminum die cast housings to prevent interference of offending noises.
- Key entries for "Quick" 16 PLUS, and 10 weather channels WX0 through WX9.

## INSTALLATION

### 2.1 UNPACKING AND INSPECTION

Use care when unpacking the unit from the shipping carton to prevent damage to the contents. It is also good practice to save the carton and the interior packing material. The original packing material should be used in the unlikely event it is necessary to return the unit to the factory.

### 2.2 EQUIPMENT SUPPLIED

The following is a list of materials supplied with the VHF 510.

Description	Part No.
Radiotelephone	M56788
Instruction Manual	G263717-1
Nicad Battery Pack	G263717-2
Wall Charger 115V AC	G263717-3
Rubber Helical Antenna w/TNC	G263717-4
Vinyl Carrying Case	G263717-5
Belt Clip w/screws	G263717-6
Wrist Strap	G263717-7
Battery Charger Bracket	G263717-9
Important Safety Messge	G263695-1
FCC Instructions	FCC Form 506

Table 2-1 Equipment Supplied

#### 2.2.1 Optional Accessories

Item #	Description	Part No.
1	Drop In Charger 12V DC/115 & 220V AC	M56791B
2	Lapel Speaker Microphone	M56368
3	High Gain Antenna	M99-127
4	Leather Carrying Case	M99-128
5	Soft Storage/Carrying Case	M99-118
6	12 Volt Cigarette Lighter Adapter	M99-126

Table 2-2 Optional Accessories

These optional accessories may be ordered by calling our Customer Service Department directly at (603) 881-9605 Monday through Friday 8:30 am - 5:00 pm E.S.T.

## 2.3 ELECTRICAL CONNECTIONS

- ① Antenna Connector (TNC Type)
- ② Speaker/Microphone Connector

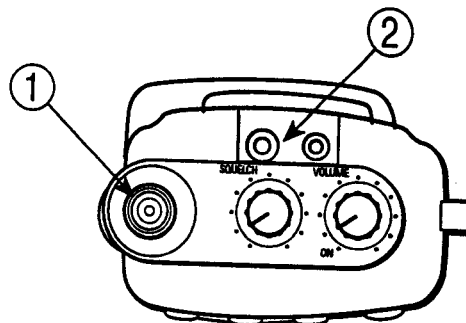

### 2.3.1 Assembly

Remove the parts from the packing material, and assemble them as follows:

- 1) Insert the battery pack into the radio from the bottom, and tighten the screw by turning it clockwise with a coin to secure the battery pack to the radio. When inserting the battery pack, align the groove at the back with the "▼" mark on the main unit.

#### Battery Pack Installation

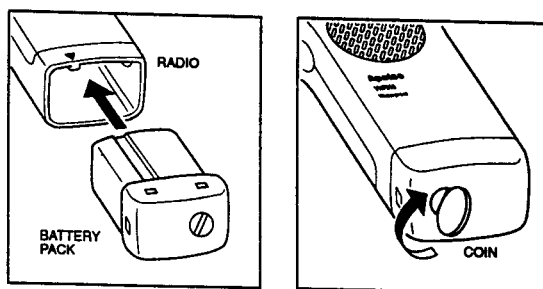

- 2) Install the wall charger bracket on a wall using the 2 screws supplied.

#### Wall Charger bracket Installation

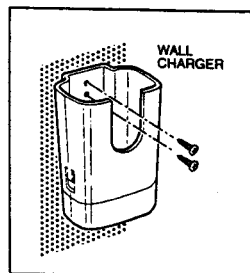

- 3) Although the battery pack has been fully charged before leaving the factory, it may be necessary to charge it prior to use. Insert the radio with the battery into the wall charger until you feel a "click". Connect the plug of AC adapter to the wall charger as shown below. A typical time required to recharge the battery pack can be up to 15 hours. Normal operating time will be an average of 6 to 8 hours on a full battery charge.

**To Charge:**

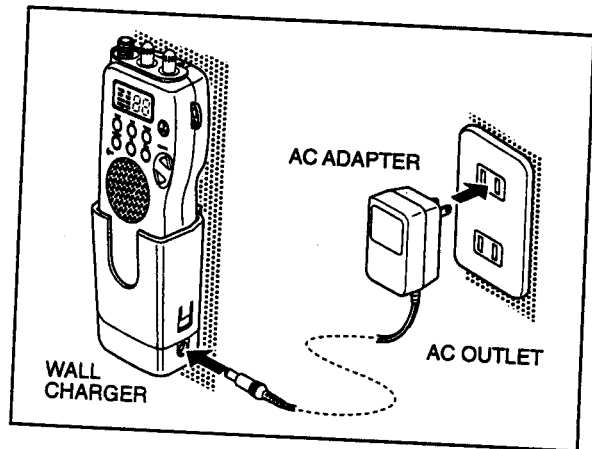

**CAUTIONS FOR CHARGING**

- \* To recharge the radio's battery pack safely, do **NOT** use any AC adapter other than the one provided.
- \* The radio should always be turned OFF while recharging the battery pack.
- \* Avoid high temperature areas (over 43 degrees Celsius) while recharging the battery pack.
- \* If the radio is to be stored for an extended period of time, remove the battery pack to avoid possible damage and/or resultant battery failure.
- \* When it is determined that the battery is no longer useful, it should be disposed properly.

- Securely fasten the rubber helical antenna to the TNC type connector on the top of the radio.

#### Antenna Installation

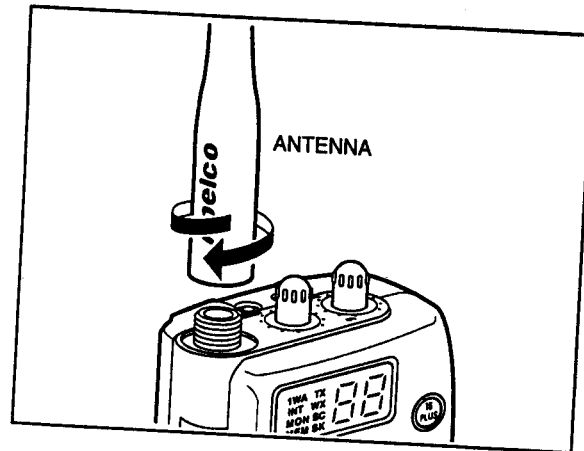

- Put the radio into the supplied carrying case if desired.
- Attach the belt clip to the back of the radio with the 2 screws supplied.
- Attach the wrist strap to the radio.

#### Belt Clip and Wrist Strap Installation

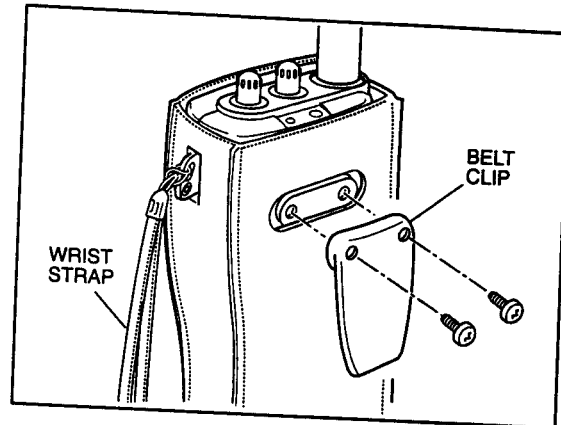

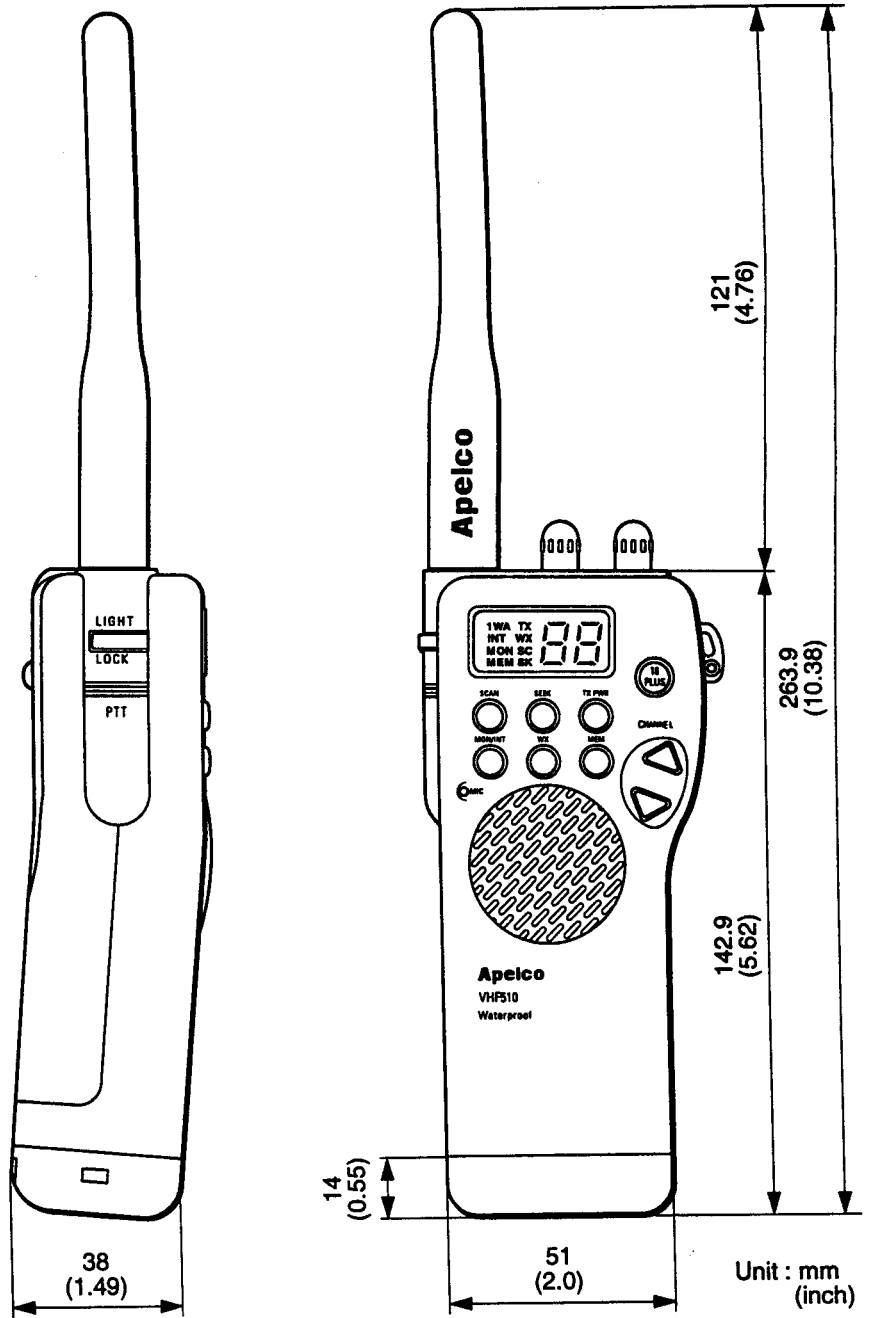

**Fig. 2-1 OUTLINE DIMENSIONS**

All dimensions are shown in inches and millimeters

---

## SECTION 3

---

# OPERATIONS

### 3.1 INTRODUCTION

Your VHF 510 has the capability to transmit on 53 and receive on 93 Marine VHF radiotelephone channels. There are channels that are FCC approved but may only be used by authorized stations for specific purposes, depending on the type of vessel (commercial or non-commercial). Take a look at Table 3-1 on page 16 & 17 which lists all of the marine VHF channels available in your VHF 510 for International and U.S. radiotelephone use. Full familiarization with this table is essential when selecting your channels. These international frequencies were agreed upon by the attending countries at the 1968 International Telecommunication Union meeting in Geneva and are in active use around the world. The U.S. channels are those channels authorized for use in the U.S.A. by the FCC.

### 3.2 CONTROLS AND LCD DISPLAY

Refer to Figure 3-1 for familiarization with the controls and mode display.

#### 3.2.1 Controls

- ① **VOLUME Control (On/Off)**  
Turns the radio On and controls the Volume of the audio output from the speaker.
- ② **SQUELCH Control**  
Provides an adjustable input signal threshold to eliminate random RF background noise during "no signal" conditions. This control sets the signal-to-noise ratio at which a signal will become audible.
- ③ **[ 16 PLUS ] Key**  
Used to select channel 16 PLUS immediately. This channel has been preset to channel 16 at the factory prior to shipment. But the channel number can be changed freely.
- ④ **[ MON/INT ] Key**  
When pressed, puts the radio into the MONITOR mode and "MON" is displayed on the LCD.  
In this mode, the radio will scan (monitor) 16 PLUS (priority) channel automatically, a selected working channel, and a weather channel for the weather alert tone.
  - When pressed and held for 2 seconds you will hear a beep and

"INT" will appear on the display. This causes the synthesizer to program International channel frequencies. When pressed and held again for 2 seconds you will again hear a beep and the synthesizer programs US frequencies. ("INT" indication disappears.) (US channels are selected in the initial setting.)

- ⑤ [ PTT ] (Push-To-Talk) Switch  
When pressed puts the radio into the transmit mode, and a character "TX" will be displayed on the LCD.
- ⑥ [ WX ] Key  
When pressed puts the radio into the Weather channel receiving mode. A "WX" will be displayed on the LCD along with the weather channel number (0-9). When in this mode, the transmitter is always disabled.
- ⑦ [ LIGHT ] (light/Key lock) Switch  
When pressed turns On/Off the backlighting of the LCD display. The display lights for five seconds. Pressing any other key will make the backlight stay on for an additional five seconds.
  - Press and hold the LIGHT key for approx. 3 seconds, an audible beep can be heard to confirm that the radio is in the key lock mode. When in this mode only the channel number is displayed on the LCD, and all keys are disabled except the PTT switch, LIGHT switch, and the VOLUME/SQUELCH controls. To exit the key lock mode, simply press and hold the LIGHT switch down until a beep is heard (approx. 3 seconds), the unit will now be out of the key lock mode.
  - The key lock mode is automatically disabled when the unit is turned off.
- ⑧ [ MEM ] Key  
This key is used to program channels into memory, or to clear channels from memory. The radio will beep to confirm when channels are being stored into memory.
- ⑨ [ TX PWR ] Key  
When pressed, alternately changes the transmitter output power from 1 watt ("1W" will be displayed) to 5 watts. ("1W" disappears.)
- ⑩ [ ▲ ] [ ▼ ] Key  
The Up and Down keys are used to move the channel numbers up or down. The channel number can be increased or decreased one with each press, or if held will continue to increase or decrease the number as long as the key is held.

- ⑪ [ SCAN ] Key  
When pressed, puts the radio into the All scan or the memory scan mode. In this mode the radio will scan channels and stop on channels receiving transmissions and monitor that channel until the transmission ceases. Simply press the Scan key to continue the scanning.
- ⑫ [ SEEK ] key  
When pressed, puts the radio into the All seek or memory seek mode. In this mode the radio will seek channels and stop on channels receiving transmissions and monitor for 7 seconds then continue the seek function.

All of the above keys will produce an audible beep when pressed.

- ⑬ Antenna Connector
- ⑭ Earphone/Microphone Connector

### WARNING!!

The VHF510 is NOT waterproof if the cover for the External Speaker /Microphone Jack is not plugged in, or is removed. To insure a waterproof seal, make sure that the waterproof cover is plugged in as shown below.

External Speaker /  
Microphone Jack Cover

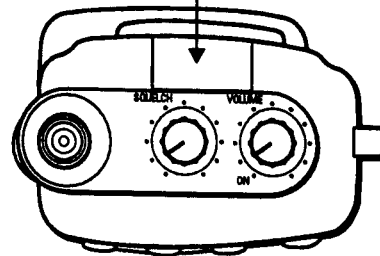

Top View of VHF510 Handheld Radio

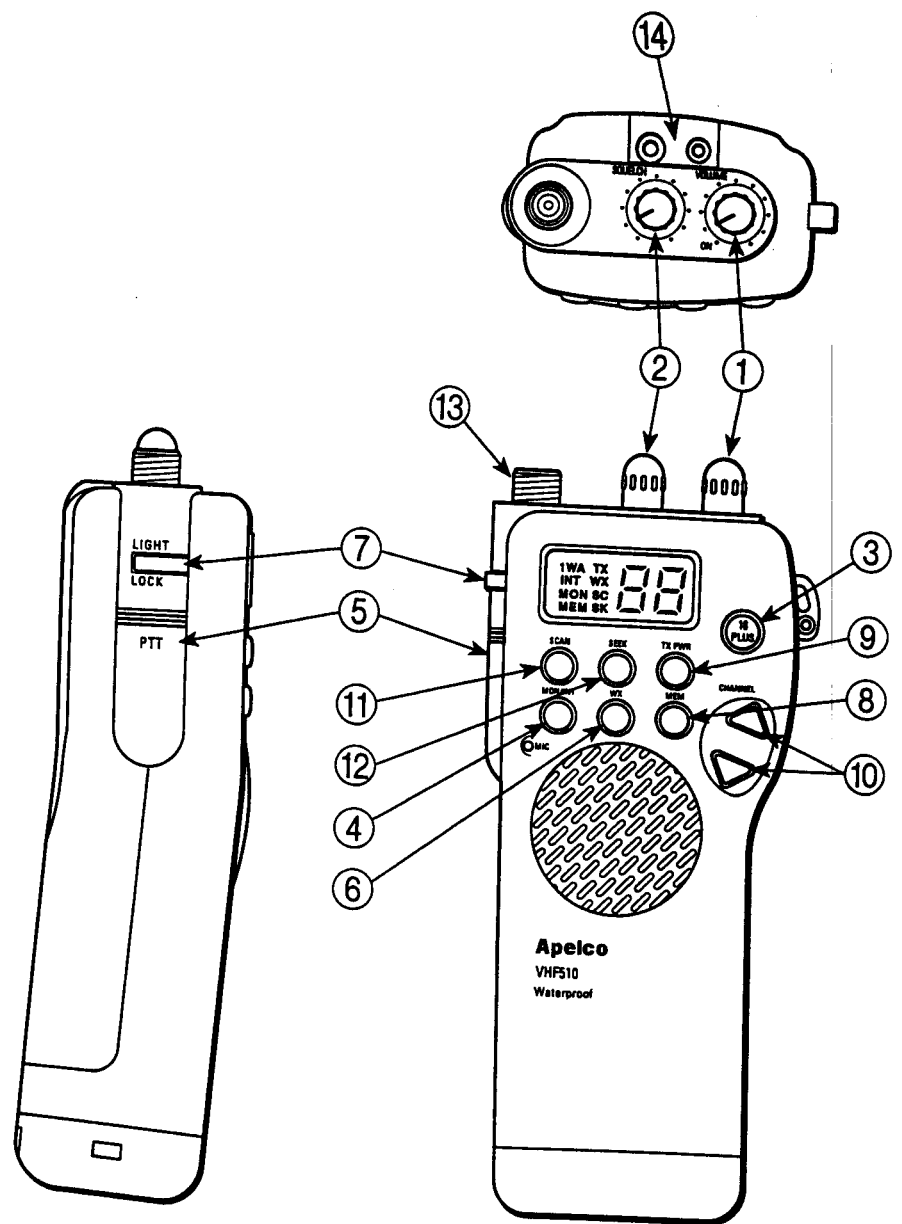

Fig. 3-1 LAYOUT OF CONTROLS AND CONNECTORS

### 3.2.2 LCD Display

A number of characters appear on the LCD display in different locations. The following list describes the characters and when and where they will appear.

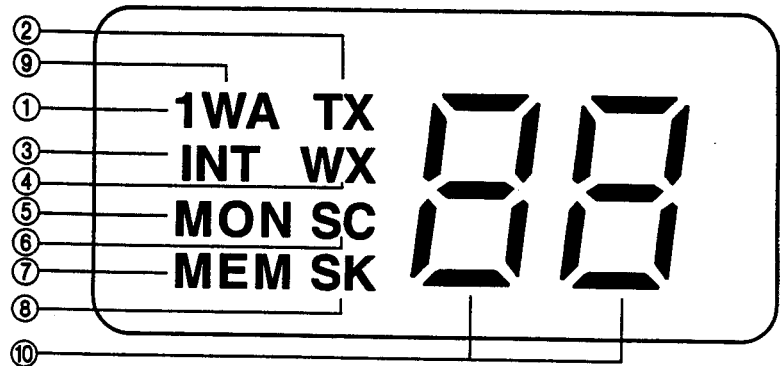

Fig. 3-2 LCD DISPLAY

- ① 1W (High/Low Power) : will be displayed when the transmitter circuits are providing 1 watt of power to the antenna, and will disappear when the transmitter circuits are providing 5 watts of power to the antenna.
- ② TX (Transmit) : will be displayed on the LCD when the Push-To-Talk switch on the radio has been pressed and the transmitter circuits are providing a signal to the antenna.
- ③ INT (International/USA) : will be displayed when International channels are programmed for use, and will disappear when US channels are programmed for use.
- ④ WX (Weather) : will be displayed when the channel selected to be monitored is a weather channel.
- ⑤ MON (Monitor) : will be displayed when the MON/INT key is pressed and the radio is in the monitor mode.
- ⑥ SC (All Scan / Memory Scan) : will be displayed when the SCAN key is pressed and the radio is in the All Scan or memory Scan mode.
- ⑦ MEM (Memory) : will blink will be displayed when the channel shown is in memory. It will also blink when the MEM key is pressed and the radio is in the memory standby mode for 2 seconds.
- ⑧ SK (All Seek / Memory Seek) : will be displayed when the SEEK key is pressed and the radio is in the All Seek or Memory Seek mode.
- ⑨ WA (Weather Alert) : will blink when a Weather Alert tone has been received.
- ⑩ LCD Segments : will display channel number in use.

### 3.3 OPERATING PROCEDURES

Specific operating procedures for the 510 are presented in this section. General information regarding correct marine channel usage may be found in the Appendix section. Refer to the Control section 3.2.1 beginning on page 7 for a thorough description of all 510 functions.

#### 3.3.1 Turning the Power On

- 1) Rotate the ON/OFF/Volume control to turn the radio on. Rotate the knob clockwise and set it at approximately the midpoint of its range.

#### NOTE

When the Power is turned on, the synthesizer automatically programs for USA channel frequencies and selects the calling channel 16. (Refer to 16 PLUS operation to change this channel)

#### Setting the Volume

- 1) Rotate the SQUELCH control fully counterclockwise, background noise will be heard.
- 2) Rotate the VOLUME control clockwise for the desired listening level out of the speaker.

#### Setting the Squelch

- 1) Rotate the SQUELCH control slowly clockwise until the background noise in the speaker ceases.

#### Setting the Power Output

- 1) Press the TX PWR key to select 1 watt ("1W" will be displayed) or 5 watts ("1W" disappears) power output. This will be dependent on the distance the message is to be transmitted, and transmitting conditions. In certain US harbors and on certain channels, the FCC requires the power to be limited to 1 watt. On these "required" channels, the radio automatically selects the 1 watt power output when the channel is selected.

#### Selecting a Channel

- 1) To select the appropriate channel you will be using, press the [ ▲ ] or [ ▼ ] channel select keys. Refer to Table 3-1 to select your "working" channel.

#### To Transmit

- Select the desired mode (INT or USA) by pressing and holding the MON/INT key for two seconds. Then simply press the Push-To-Talk switch and speak into the microphone using a clear normal voice.
- When the power is initially turned on, simply press the Push-To-Talk switch, the radio will be ready for transmission on CH16 or a user selected priority channel (16 PLUS).

The 510 is designed to meet the new FCC Rules Part 80.203. Which states, if the Push-To-Talk switch is pressed for over five minutes continuously, transmission is forcibly inhibited. If this occurs audible beeps will sound until the Push-To-Talk switch is released. While, "TO (time out)" blinks on the LCD. After releasing the Push-To-Talk switch, the radio is ready for reception.

#### NOTES

1. Initial communication contacts are usually made over channel 16 as all ships and shore stations monitor this channel, then a shift to a working channel will be necessary.
2. If low battery is detected during transmission, selected channel number and "LO (low battery)" are alternately displayed on the LCD.

#### To Select A Weather Channel

- 1) Press the WX key, then the up [ ▲ ] or down [ ▼ ] key to select the desired weather channel from 0 to 9. When this mode is selected, the transmitter is always inhibited.
- 2) If a weather alert signal is received on your selected WX channel (when in the Monitor Mode) there is a 5-second audible alarm generated. To cancel the audible alarm, simply press any key.

#### 3.3.2 The 16 PLUS (priority) Channel

The 16 PLUS channel has been preset to the CH 16 prior to shipment from the factory. But the 16 PLUS channel can be changed freely, with the exception of all weather channels.

- 1) Press the Up [ ▲ ] or Down [ ▼ ] key to select the desired channel. Then press and hold the 16 PLUS key for three seconds. An audible beep tone will confirm that the selected channels is stored in memory as the 16 PLUS channel.
- 2) To set CH 16 as the 16 PLUS channel again, repeat step 1 for CH 16.

### 3.3.3 Channel Memory

The VHF 510 has the capability of scanning up to a maximum of 10 channels in the INT/US mode.

- 1) Channel Memory : To put a channel into memory simply select the channel to be stored in memory with the up & down arrows to show on the display. Push and hold the MEM key down until a beep is heard (approx. 2 seconds), the beep tone confirms that the channel has been entered into memory. This procedure can be repeated for a total of 10 channels. If channel memory is full, FL will appear on the display when you attempt to memorize a channel. To program more channels you must first clear some of the existing channels from memory.
- 2) Memory Clear : To clear a memorized channel, simply select the channel to be cleared on the display, then press and hold down the MEM key until a beep tone is heard (approx. 2 seconds) and MEM disappears from the display. This procedure may be repeated to clear all or selected channels from memory.
- 3) Memory Recall : To review the memorized channels, simply press the MEM key and then press the MEM key again while the "MEM" indicator is blinking. This will sequentially display the memorized channels at 0.5 second intervals.

### 3.3.4 Master Reset

If you hold down the MEM key when turning the power on, all channels will be cleared from memory and the 16 PLUS channel will be automatically programmed back to channel 16.

### 3.3.5 Scan Mode

- 1) All Channel Scan : When the SCAN key is pressed, the radio will start scanning all channels from the one displayed in an upward direction. If a signal is received, the scanning will stop (will hold on displayed channel) until signal is no longer received, then, after 5 seconds it will continue to scan. While the scanning has stopped on a received signal you may simply press the SCAN key to continue the scanning. To cancel the scanning, press and hold the SCAN key for 2 seconds or simply press any key except the TX PWR key.
- 2) Memory Channel Scan : To scan only the memorized channels, press the MEM key and then press the SCAN key while "MEM" is blinking for 2 seconds. Other operation is identical to all scan.

### 3.3.6 Seek Mode

- 1) All Channel Seek : When the Seek key is pressed, the radio will start seeking all channels from the one displayed in an upward direction. If a signal is received, seeking will stop (will hold on displayed channel for 7 seconds), then continue seeking. Press any key except the TX PWR key to cancel the seek operation.
- 2) Memory Channel Seek : To seek only the memorized channels, press the MEM key and then press the SEEK key while "MEM" is blinking for 2 seconds. Other operation is identical to all seek.

### 3.3.7 Monitor Mode

Before entering the Monitor Mode you must first select the WX channel you wish to monitor for the weather alert tone. Next, you must also select a working channel to be monitored for traffic. Then, simply press the MON/INT key and the radio will begin to scan channel 16 PLUS, 83, WX2, repetitively. In this example, we used channel 83 as our working channel and WX2 as our weather channel. The 16 PLUS channel programmed into the radio is automatically selected as one of the monitored channels. To cancel the Monitor mode, press any key except "TX PWR" key.

#### Working Channel

If a signal is received on CH 83, the scan will stop on CH 83, but will continue to monitor 16 PLUS and the selected weather channel every five seconds.

#### 16 PLUS (priority) Channel

If while scanning a signal is received on 16 PLUS, the scanning will stop on 16 PLUS for as long as the signals being received. If the signal ceases for more than five seconds, the scanning will continue.

#### Weather CH

Until a weather alert tone signal is received on WX2, the scan will stop on WX2 briefly, but will not give any audio output. When a weather alert tone (1050 Hz) is received, the monitor will stop and an audible alarm will sound for five seconds. To silence the alarm, simply push any key.

### 3.3.8 VHF 510 Marine Channels and Their Usage

#### CAUTION

\* The transmitter of the VHF 510 is disabled when channel 15 or WX0 - WX9 is displayed.

CHANNEL DESIGN.	FREQUENCY (MHz)			TYPE OF TRAFFIC	FUNCTION	
	TX	RX (USA)	RX (INT'L)		SHIP TO SHIP	SHIP TO SHORE
01#	156.050	156.050	160.650	-	-	-
02#	156.100	156.100	160.700	-	-	-
03#	156.150	156.150	160.750	-	-	-
04#	156.200	156.200	160.800	-	-	-
05	156.250	156.250	160.850	Port Operations	Yes	Yes
06	156.300	156.300	156.300	Intership Safety	Yes	No
07	156.350	156.350	160.950	Com'l	Yes	Yes
08	156.400	156.400	156.400	Com'l	Yes	No
09	156.450	156.450	156.450	Call & Ship/Ship	Yes	Yes
10	156.500	156.500	156.500	Com'l & Ship/Ship	Yes	Yes
11	156.550	156.550	156.550	Com'l & Ship/Ship	Yes	Yes
12	156.600	156.600	156.600	Port Operations	Yes	Yes
13**	156.650	156.650	156.650	Nav. Ship/Bridge	Yes	Yes
14	156.700	156.700	156.700	Port Operations	Yes	Yes
15#	-	156.750	156.750	Environmental	-	-
16	156.800	156.800	156.800	Emerg/Calling	Yes	Yes
17*	156.850	156.850	156.850	State Controlled	Yes	Yes
18	156.900	156.900	161.500	Com'l	Yes	Yes
19	156.950	156.950	161.550	Com'l	Yes	Yes
20	157.000	157.000	161.600	Port Operations	Yes	Yes
21 (CG)	157.050	157.050	161.650	Coast Guard	Yes	Yes
22 (CG)	157.100	157.100	161.700	Coast Guard	Yes	Yes
23 (CG)	157.150	157.150	161.750	Coast Guard	Yes	Yes
24	157.200	161.800	161.800	Public Corresp	No	Yes
25	157.250	161.850	161.850	Public Corresp	No	Yes
26	157.300	161.900	161.900	Public Corresp	No	Yes
27	157.350	161.950	161.950	Public Corresp	No	Yes
28	157.400	162.000	162.000	Public Corresp	No	Yes
60+	156.025	156.025	160.625	-	-	-
61+	156.075	156.075	160.675	-	-	-
62+	156.125	156.125	160.725	-	-	-
63	156.175	156.175	160.775	Com'l	Yes	Yes
64+	156.225	156.225	160.825	-	-	-

Table 3-1

- \* 1 watt only
- \*\* 1 watt initially. User can override to high power (5 watts) via front panel controls.
- # The transmitter is automatically disabled when channels 1, 2, 3, and 4, for USA; and 15 for USA and International are selected.
- + Assigned by Canadian Government, proper authorization must be ensured prior to use.

**Caution**

\* Operation on channels not designated for use by your classification or craft or on International Channels within the US territorial waters is a violation of FCC Rules and Regulations and may result in severe penalties.

CHANNEL DESIGN.	FREQUENCY (MHz)			TYPE TRAFFIC	FUNCTION	
	TX	RX (USA)	RX (INT'L)		SHIP TO SHIP	SHIP TO SHORE
65	156.275	156.275	160.875	Port Operations	Yes	Yes
66	156.325	156.325	160.925	Port Operations	Yes	Yes
67**	156.375	156.375	156.375	Com'l	Yes	No
68	156.425	156.425	156.425	Non Com'l	Yes	Yes
69	156.475	156.475	156.475	Non Com'l	Yes	Yes
70#	-	156.525	156.525	DSC	Yes	Yes
71	156.575	156.575	156.575	Non Com'l	Yes	Yes
72	156.625	156.625	156.625	Non Com'l	Yes	No
73	156.675	156.675	156.675	Port Operations	Yes	Yes
74	156.725	156.725	156.725	Port Operations	Yes	Yes
75#	-	156.775	156.775	-	-	-
76#	-	156.825	156.825	-	-	-
77*	156.875	156.875	156.875	Port Operations	Yes	No
78	156.925	156.925	161.525	Non Com'l	Yes	Yes
79	156.975	156.975	161.575	Com'l	Yes	Yes
80	157.025	157.025	161.625	Com'l	Yes	Yes
81	157.075	157.075	161.675	Coast Guard	Yes	Yes
82	157.125	157.125	161.725	Coast Guard	Yes	Yes
83	157.175	157.175	161.775	Coast Guard	Yes	Yes
84	157.225	161.825	161.825	Public Corresp.	No	Yes
85	157.275	161.875	161.875	Public Corresp.	No	Yes
86	157.325	161.925	161.925	Public Corresp.	No	Yes
87	157.375	161.975	161.975	Public Corresp.	No	Yes
88	157.425	157.425	162.025	Com'l	Yes	No

**Table 3-1 (Continued)**

- \* 1 watt only
- \*\* 1 watt initially. User can override to high power (5 watts) via front panel controls.
- # The transmitter is disabled when channels 75 and 76 are selected. Channel 70 is now used for DSC calling only, therefore transmission is disabled on channel 70 in this radio.

CHANNEL	FREQUENCY (MHz)	TYPE TRAFFIC	FUNCTION-SHIP TO SHORE
WX0	163.275	NOAA Weather	Receive Only
WX1	162.550	NOAA Weather	Receive Only
WX2	162.400	NOAA Weather	Receive Only
WX3	162.475	NOAA Weather	Receive Only
WX4	162.425	NOAA Weather	Receive Only
WX5	162.450	NOAA Weather	Receive Only
WX6	162.500	NOAA Weather	Receive Only
WX7	162.525	NOAA Weather	Receive Only
WX8	161.650	NOAA Weather	Receive Only
WX9	161.775	Canadian Weath.	Receive Only
		Canadian Weath.	Receive Only

**Table 3-2**

**Caution**

- \* Operation on channels not designated for use by your classification of craft or on International Channels within US territorial waters is a violation of FCC Rules and Regulations and may result in severe penalties.

---

## SECTION 4

---

### TECHNICAL DESCRIPTION

#### 4.1 GENERAL

The VHF 510 can be considered as consisting of two major sections. They are :

- The Control Circuitry (consisting of the front panel controls, the LCD display, control CPU).
- The Transmitter/Receiver/PLL circuits.

#### 4.2 THE CONTROL SECTION

The heart of the control section is the CPU, which is IC400 located on the CPU PCB. The CPU controls all of the following items :

- controls the Squelch circuit by detecting a busy signal from the 2nd IF circuit IC301.
- generates a beep tone when a key is activated on the keyboard.
- mutes the transmitter modulation circuit when receiving.
- controls the output power of the transmitter High/Low.
- controls the dividing ratio N of the PLL circuit.
- switches On/Off the transmitter power.
- mutes AF audio.
- detects a weather alert signal (when in Monitor Mode).
- controls the LCD display.

#### 4.3 THE TRANSMITTER/RECEIVER/PLL SECTIONS

In reading through the following circuit descriptions, it may be helpful to refer to Figure 4-1 Block Diagram of the TX/RX/PLL circuits.

##### 4.3.1 PLL (Phase Lock Loop) Circuit

The PLL circuit is the frequency synthesizer in the VHF 510.

The reference frequency of 12.8 MHz is provided by crystal F151 and IC151. IC151 contains the reference oscillator (12.8 MHz) circuit, the phase comparator, the program counter and the phase detector.

The 12.8 MHz reference signal is divided by 512 in the program counter in IC151 to obtain a 25 KHz reference signal. The dividing ratio is determined by CPU IC400. The VCO output from oscillator Q103 is amplified by buffer amplifier Q104, and returned to

IC151 and is divided by the dividing ratio N to obtain a 25 KHz signal. N for 1/N in IC151 is determined by CPU IC400. Both of these 25 KHz signals are fed into the phase comparator circuit of IC151.

The phase detected signal, obtained by comparing the phase difference between these two signals, is applied to LPF between pins 11 and 12 of IC151 to get a DC voltage correlated with the phase difference.

This DC voltage acts on the VCO to make the two 25 KHz signals the same phase. When this condition is met, the PLL circuit is locked. If the two signals have a large phase difference, the PLL is unlocked. In this condition, the unlocked signal is fed to CPU IC400 from IC151 and the transmitter is compelled to stop.

The VCO output from Q103 is fed to the TX amplifier Q303 and the first RX mixer Q310 through buffer amplifier Q102.

#### 4.3.2 Transmitter Circuit

A signal from the microphone is fed to a pre-emphasis operational amplifier IC201 (A, B), deviation limiter circuit D201, and modulates VCO (Q103) through active LPF IC201 (C, D).

The VCO output signal from Q103 is sent to the RF power amplifiers Q301 to Q303 through buffer amplifier Q102. The RF signal from Q301 is fed to the antenna through a low pass filter.

The DC voltage correlative to the RF output is detected by D303, amplified by Q306 Q308 and fed to Q301. The output voltage from Q301 controls the RF power to keep the RF output at a constant level.

#### 4.3.3 Receiver Circuit

##### 1) RF Circuit

The signal from the antenna passes through the single tuned band pass filter and is amplified by RF amplifier Q309, and is fed into a triple tuned band pass filter. The signal is then mixed Q102 (lock freq.) by Q310 (first mixer) and produces the first IF signal of 21.6 MHz. This signal is sent to a crystal filter (21.6 MHz) and 1st IF amplifier Q311, mixed by IC301, the 2nd mixer and becomes an audio signal after detection.

##### 2) AF Circuit

The AF signal from IC301 is amplified by IC205 to drive the speaker while the receiver is in the squelched condition. Muting control of IC205 is carried out by the CPU IC400 through Q203.

##### 3) Weather Alert Tone Detecting Circuit

If a weather alert tone is included in the AF signal from IC301 while receiving the weather service broadcast, IC204 detects it and notifies an alert condition to the CPU IC400.

##### 4) IF Circuit

The output of the 1st IF amplifier Q311 is fed into IC301. IC301 contains second mixer, second local oscillator, 455 KHz amplifier, quadrature detector and DC switching amplifier.

A 455 KHz ceramic filter is installed between pins 3 and 5 of IC301 to examine the selectivity of this unit.

The detector output is separated into audio and noise components by an RC filter. The noise component is fed back to the noise amplifier section of IC301. Its output is rectified by a diode in IC301, and then fed to the switching amplifier in IC301.

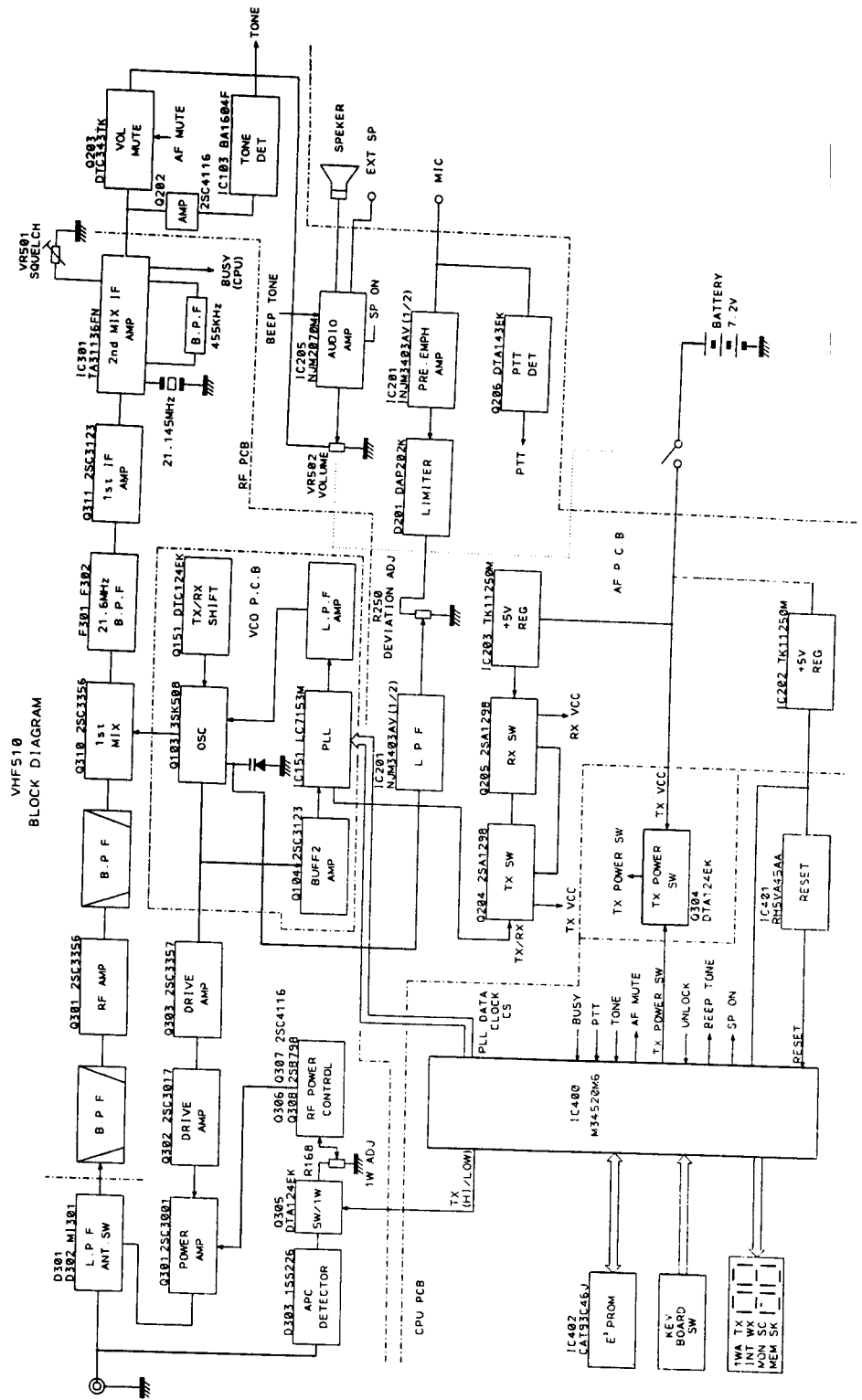

Fig. 4-1 VHF 510 BLOCK DIAGRAM

Intermodulation Rejection	Greater than 60 dB
Audio Output	0.3 Watt or more at 10% or less distortion into 8 Ohm load
Hum & Noise in Audio	Less than -40 dB

#### Operating Requirements

Input Voltage	7.2 Vdc Nicad rechargeable battery
Battery Capacity	600 mA/H
Current Required	
Transmit	Less than 2.8 amp at 5 Watts Less than 1.4 amp at 1 Watt
Receiving (squelched)	Less than 70 mA; 200 mA at 0.3 Watt audio output (1 KHz)
Operating Temperature	-20°C to +50°C
Duty Cycle	Continuous, 80% receive, 20% transmit (max 10 min. @ 25°C)
Humidity	100% at 50°C for 8 hours

#### Radio Dimensions

Height	143 mm (5.6 inches)
Width	58 mm (2.3 inches)
Depth	41 mm (1.6 inches)
Weight	Approx. 0.5 kg. (1 lb)

#### NOTE

The VHF 510 VHF-FM radiotelephone meets all applicable sections of FCC Rules Parts 2, 15 and 80.

- 3) Inspect the radio case, battery pack, and antenna for any physical damage.
- 4) Check the antenna connector, and external microphone/speaker jack for any dirt or corrosion.

**NOTE**

The following alignment procedures have been provided in this manual to aid FCC licensed technicians and service personnel only!

### 5.3 ALIGNMENTS AND SERVICE

This transceiver is completely aligned at the factory and does not require any adjustments at installation.

The test equipment listed below are used for the test setup shown in Fig.5-1. This test setup is used either in part or in total during the following adjustments.

**TEST EQUIPMENT**

1. DC Power Supply (0 – 20 V variable, 3A max.) set at 7.2 Vdc
2. RF Power Meter (10 W, 50 ohm, 150 – 200 MHz)
3. RF Signal Generator (50 ohm Output, 150 – 200 MHz)
4. FM Linear Detector (FMLD) or Deviation Monitor 150 – 200 MHz
5. Frequency Counter
6. Digital Voltmeter
7. Oscilloscope (any oscilloscope accurate for audio signal tracing)
8. SINAD Meter
9. Distortion Meter
10. Toggle Switch (for use as a PTT switch)
11. Coaxial Switch for TX/RX Antenna switching

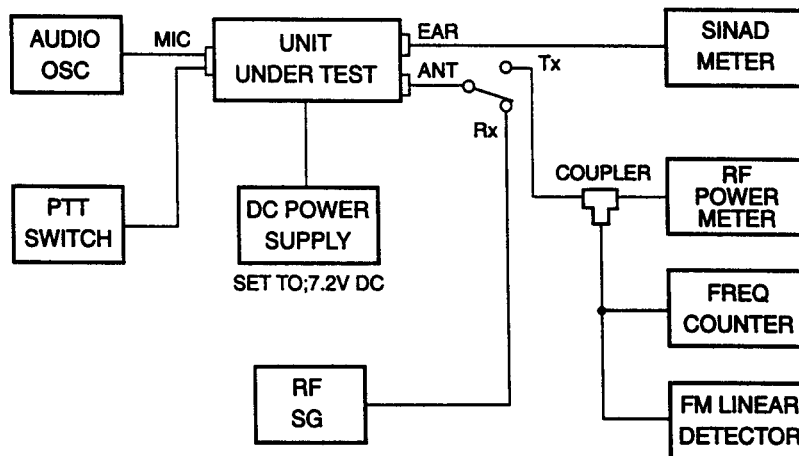

**Fig. 5-1 TEST SETUP**

### 5.3.1 PLL Adjustment (TRANSMITTER/RECEIVER)

- 1) Connect the power supply (7.2 V, 3 A) to the power line and the PTT switch to the microphone terminal.
- 2) Connect a digital voltmeter or high impedance tester (positive lead to TP1, negative to ground) and adjust C117 and C118 on the VCO PCB as shown in Table 5-1. (See Fig. 5-2.)

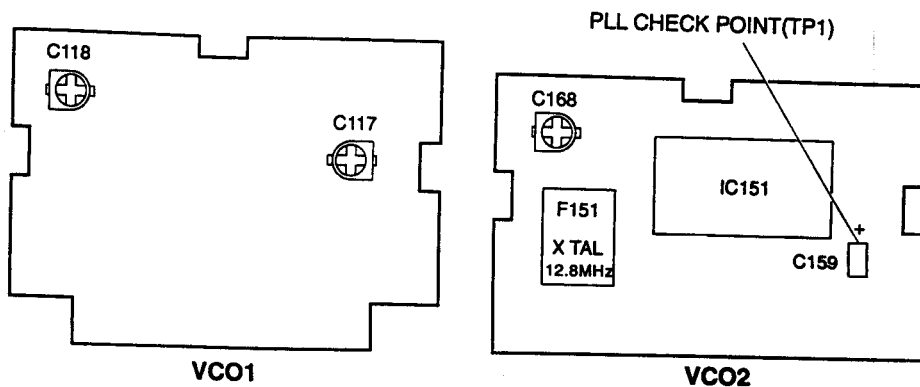

Fig. 5-2 VCO PCB (1/2)

Sequence	Item	Condition	Adj. point	Adj. volt.
1	TX	transmit CH.16 USA	C118	2.1 Vdc or Minimum
2	RX	receive CH.60	C117	1.3 ± 0.1 Vdc
3	RX	receive WX0	---	check for less than 3.8 Vdc

Table 5-1

### 5.3.2 Frequency Adjustment (TRANSMITTER)

- 1) Connect the coupler output to a frequency counter, set the radio on CH16 (156.800 MHz), key to transmit, and read the indication on the frequency counter.
- 2) Adjust trimmer capacitor C168 on the VCO PCB for the desired frequency (156.800 MHz) ± 200 Hz on the frequency counter.

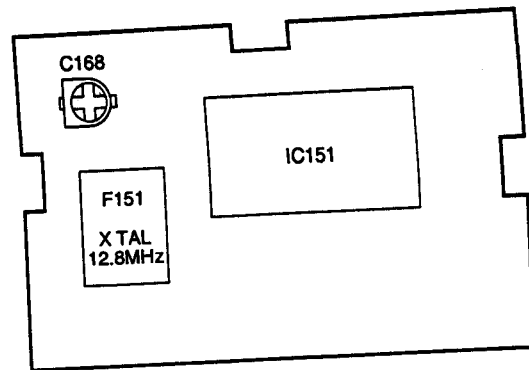

Fig. 5-3 VCO PCB (2/2)

### 5.3.3 Modulation Adjustment (TRANSMITTER)

- 1) Connect the coupler output to an FM linear detector.  
Connect an audio oscillator to the microphone connector and key to transmit.
- 2) Set the audio oscillator output to  $-20$  dB $\mu$ , 300 Hz and adjust R250 on the AF PCB for a deviation of  $4.5$  KHz  $\pm$  300 Hz. (See Fig. 5-4.)
- 3) Set the audio oscillator output to  $-43$  dBm, 1 KHz and read the deviation meter ( $\pm 2.5$  KHz  $- \pm 3$  KHz)

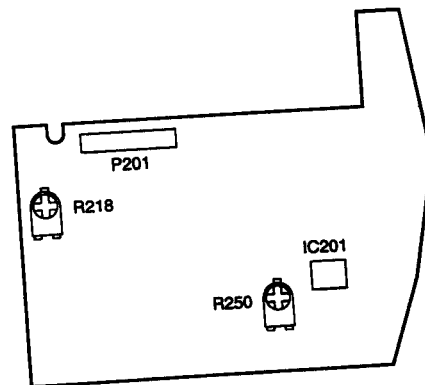

Fig. 5-4 AF PCB

### 5.3.4 Power Output Adjustment (TRANSMITTER)

- 1) Connect an RF power meter to the antenna connector through the coupler. Key to transmit and adjust R350 on the RF PCB as shown in Table 5-2. (See Fig. 5-5.)

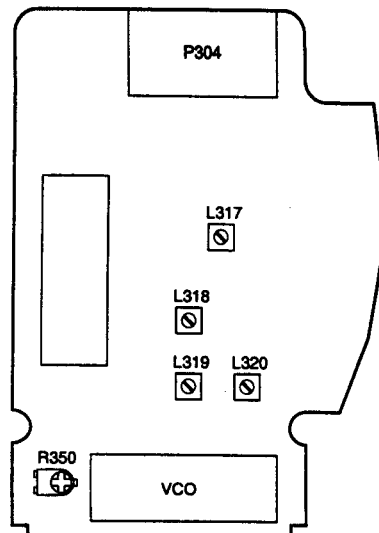

Fig. 5-5 RF PCB

Sequence	Condition	Adj. point	Target power
1	7.2 Vdc H/L: L	R350 low power	0.9 W $\pm$ 0.05 W (limit 1.0 W)
2	7.2 Vdc H/L: H	check	5 W (over 4.5 W)

Table 5-2

### 5.3.5 RF Sensitivity Adjustment (RECEIVER)

- 1) Connect an RF signal generator to the antenna connector and a SINAD meter to the EAR (external speaker) jack. Set the deviation of the RF signal generator to 1 KHz  $\pm$  3 KHz.
- 2) Set the output level of the RF signal generator and adjust L317 – L320 on the RF PCB as shown in Table 5-3. (See Fig. 5-5.)

Sequence	Condition	Adj. point	Target level
1	CH.88 (157.425 MHz) SG output: 40 dB $\mu$	L317 - L320	Max. sensitivity
2	CH.16 SG output: -6 dB $\mu$	L319	Over 12 dB SINAD

Table 5-3

### 5.3.6 Weather Alert Frequency Adjustment (RECEIVER)

- 1) Connect an RF signal generator to the antenna connector.  
Set the RF signal generator as follows:
  - Frequency: 162.550 MHz with no modulation
  - Output level: 60 dB $\mu$ .
- 2) Select the weather channel WX1.
- 3) Connect a frequency counter to TP1 on the AF PCB and adjust R218 to obtain 1050 kHz  $\pm$  5 Hz on the frequency counter. (See Fig. 5-6.)

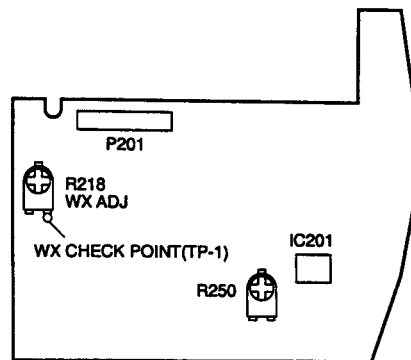

Fig. 5-6 AF PCB

## 5.4 TROUBLESHOOTING GUIDE

Table 5-4 provides a general troubleshooting chart for use by a technician to isolate circuitry failures to specific functional areas within the VHF radio.

The first step in attempting to clear a problem associated with the general operation of this radio is to perform a **MASTER RESET**. This can be done by simply holding down the MEM key while turning the radio on. This should be performed anytime a component or PCB within a radio is replaced. This function will clear the memory of the 510 and return it to the original factory settings, 16 PLUS will automatically be reprogrammed to channel 16.

### NOTE

Micro-components within the radio are generally not field replaceable, therefore, repairs to the radio typically go down to the PC board level only. A replacement parts list for the VHF 510 can be found in Section 6.

Item Number	Symptom	Possible Cause
1	Unit does not turn on.	a. Defective power switch. b. Check the battery voltage. c. Capacitor C384 shorted. d. Defective regulator IC202.
2	No sound with AF signal applied to pin 2 of IC205	a. Defective speaker jack. b. Defective IC205 and/or associated components (C248, etc.). c. Defective speaker ON control circuit (Q207).
3	No sound with AF signal applied to volume control	a. Defective volume control. b. Defective mute circuitry (Q203).
4	Squelch circuit inoperative	a. Check squelch control. b. Defective IC301 and/or associated circuitry between pins 7 and 9.

Table 5-4 TROUBLESHOOTING CHART

Item Number	Symptom	Possible Cause
5	No receive (RX)	<ul style="list-style-type: none"> <li>a. Defective regulator IC203.</li> <li>b. Defective Q205 (RX+B).</li> <li>c. Check IC301 audio output voltage at pin 9.</li> <li>d. Defective audio signal buffer Q312.</li> <li>e. Check F304 output for 21.145 MHz signal.</li> <li>f. Check 21.6 MHz output of first mixer Q310.</li> <li>g. Check 21.6 MHz output of ceramic filters F301 and F302.</li> <li>h. Check 21.6 MHz output of first IF amplifier Q311.</li> <li>i. Check 455 KHz signal from ceramic filter F305.</li> <li>j. Failure of VCO circuit (Q102, Q103, Q104, and/or PLL IC151).</li> <li>k. Defective CPU.</li> </ul>
6	Low receiver sensitivity	<ul style="list-style-type: none"> <li>a. Check antenna and connector for possible corrosion or bad connection.</li> <li>b. Failure of the output from Q309, Q310, Q311, and/or IC301.</li> <li>c. Check the output level of VCO per para. 5.3.1.</li> </ul>
7	CPU inoperative	<ul style="list-style-type: none"> <li>a. Turn off the power once, and try again.</li> <li>b. Check CPU clock frequencies (pins 22 and 23, and pins 26 and 27 of IC400).</li> <li>c. If clock frequency is not present, check for +5 Vdc line.</li> </ul>
8	Display malfunction	<ul style="list-style-type: none"> <li>a. Check the interconnection to the LCD display.</li> <li>b. Inoperative CPU.</li> </ul>

Table 5-4 (Continued)

Item Number	Symptom	Possible Cause
9	No transmit (TX)	<ul style="list-style-type: none"> <li>a. Defective PTT switch.</li> <li>b. Defective regulator IC203.</li> <li>c. Defective Q204 (TX+B).</li> <li>d. Check power transmit circuit (Q301, Q302, and/or Q303).</li> <li>e. Failure of VCO circuit (Q102, Q103, and/or Q104) or PLL IC151.</li> <li>f. Check PLL control voltage for 3.0 V at TP1 on channel 16.</li> <li>g. Failure of TX mute circuit (Q304).</li> <li>h. Failure of talk detection circuit (Q206).</li> </ul>
10	Low RF power output	<ul style="list-style-type: none"> <li>a. Check RF power output from Q301. If it checks good, then check the triple Pi type network components (C301-304 and L301-303) and antenna switching diode (D302). If not good, then check the voltage level outputs of the drive amplifiers Q302 and Q303 as well as the associated circuitry.</li> <li>b. Check power control circuit (Q305, Q306, Q307, and/or Q308).</li> </ul>
11	Poor or no modulation	<ul style="list-style-type: none"> <li>a. Defective microphone or microphone jack.</li> <li>b. Defective IC201 and/or its associated components.</li> </ul>
12	Deviation of transmit frequency	<ul style="list-style-type: none"> <li>a. Check VCO output frequency at pin 14 of PLL IC151, PLL phase detector output at pin 12 of PLL IC151, and associated circuitry.</li> <li>b. Check 12.8 MHz crystal (F151).</li> </ul>
13	PLL output frequency or level incorrect	<ul style="list-style-type: none"> <li>a. Check frequency of 12.8 MHz crystal (F151).</li> <li>b. Check the frequency output at pin 14 of IC151 and verify the transmit frequency.</li> </ul>

Table 5-4 (Continued)

# SECTION 6

## PARTS LIST AND DRAWINGS

### 6.1 PARTS LOCATION LIST

#### COMPONENT UNIT

LOCATION No.	DESCRIPTION	RMC Part No.
1	CHARGER (VHF) UNIT	

#### ACCESSORIES

LOCATION No.	DESCRIPTION	RMC Part No.
1	M.LABEL VHF510	
2	M.KIT VHF510	
3	AC ADAPTOR DC12200	
4	SCREW KIT	
5	SCREW KIT	
6	HOLDER (CLIP)	
7	ANT-AP-156	
8	CARRYING STRAP	
9	C.CASE (VHF)	
10	PLASTIC BAG 100X250	
11	PLASTIC BAG 100X100	
12	STYROFOAM	
13	GIFT BOX VHF510	
14	MASTER CARTON (4)	
15	S.NO LABEL	
16	S.NO LABEL	

# RF CIRCUIT BOARD (35L9710/36C9810)

LOCATION No.	DESCRIPTION	RMC Part No.
C378	CAPACITOR,CHIP,0.022UF 25V	
C382 ,C383	CAPACITOR,CHIP,1000PF 50V	
C384	CAPACITOR,CHIP,1000PF 50V	
D301 ,D302	DI-MI301	
D303	DIODE,1SS226T	
D304 ,D305	DIODE,DA204KT	
D306 ,D307	DIODE,1SV156	
D308	DIODE,DAN202KT	
F301 ,F302	X'TAL,MF-21.6-RB	G263479-17
F303	CF-CDBM455C24	
F304	X'TAL,21.145MHZ	
F305	CERAMIC FILTER,CFWM455E	
IC301	IC,TA31136FN-CT	G263718-2
L301 ,L302	COIL,1R5-5TL	
L303 ,L304	COIL,1R5-5TL	
L305 ,L316	COIL,LQH1N6R8M04-CT	
L306 ,L307	COIL,1R25-5TL	
L308 ,L310	L-1R25-4TL	
L309 ,L314	COIL,LQH1N1R0M04-CT	
L312 ,L313	L-1R25-4TL	
L315	COIL,LQH1N1R2M04-CT	
L317	COIL,ANT-VHF510-CT	
L318	COIL,RF1-VHF510-CT	
L319	COIL,RF2-VHF510-CT	
L320	COIL,RF3-VHF510-CT	
N301	COAXIAL 0.8D-2V	
N302	WIRE ##	
P301	POST-9210B-1-14Z147T	
P302	POST-9210B-1-10Z147T	
P303	POST-IL-S-2PS5	
P304	CONN-HSJ1468-01-010	
Q301	TRANSISTOR,2SC3001	
Q302	TRANSISTOR,2SC3017	
Q303	TRANSISTOR,2SC3357T-E.F	
Q304 ,Q305	TRANSISTOR,DTA124EKT	
Q306 ,Q307	2SC4116T-G,L	
Q308	2SB798T-K,L	
Q309 ,Q310	TRANSISTOR,2SC3356T-24,25	
Q311	2SC3123T	
Q312	2SC4116T-G,L	
R301	RESISTOR,CHIP,680OHM 1/16W	
R302	RESISTOR,CHIP,180OHM 1/4W	
R303	RESISTOR,CHIP,120KOHM 1/16W	
R304 ,R321	RESISTOR,CHIP,220OHM 1/16W	

**RF CIRCUIT BOARD (35L9710/36C9810)**

<b>LOCATION No.</b>	<b>DESCRIPTION</b>	<b>RMC Part No.</b>
R305 ,R318	RESISTOR,CHIP,10KOHM 1/16W	
R306	RESISTOR,CHIP,33KOHM 1/16W	
R307 ,R308	RESISTOR,CHIP,100OHM 1/16W	
R309	RESISTOR,CHIP,4.700OHM 1/16W	
R310 ,R311	RESISTOR,CHIP,100OHM 1/16W	
R312 ,R313	RESISTOR,CHIP,330OHM 1/16W	
R314	RESISTOR,CHIP,68KOHM 1/16W	
R315 ,R322	RESISTOR,CHIP,47OHM 1/16W	
R316	RESISTOR,CHIP,100OHM 1/16W	
R317 ,R331	RESISTOR,CHIP,3.3KOHM 1/16W	
R319	RESISTOR,CHIP,10KOHM 1/16W	
R320	RESISTOR,CHIP,5.6KOHM 1/16W	
R323 ,R324	RESISTOR,CHIP,330OHM 1/16W	
R325	RESISTOR,CHIP,18OHM 1/16W	
R326	RESISTOR,CHIP,1KOHM 1/16W	
R327 ,R330	RESISTOR,CHIP,1.5KOHM 1/16W	
R328 ,R336	RESISTOR,CHIP,100KOHM 1/16W	
R329 ,R342	RESISTOR,CHIP,220OHM 1/16W	
R332	RESISTOR,CHIP,150KOHM 1/16W	
R333	RESISTOR,CHIP,47KOHM 1/16W	
R334 ,R351	RESISTOR,CHIP,1.5KOHM 1/16W	
R337	RESISTOR,CHIP,820OHM 1/16W	
R338	RESISTOR,CHIP,2.2KOHM 1/16W	
R339	RESISTOR,CHIP,100KOHM 1/16W	
R340	RESISTOR,CHIP,220KOHM 1/16W	
R341	RESISTOR,CHIP,6.8KOHM 1/16W	
R350	RVC-RVG4M01-103-CT	

## AF CIRCUIT BOARD (35L9720/36C9820)

LOCATION No.	DESCRIPTION	RMC Part No.
C201 ,C238	CAPACITOR,ELECTROLYTIC,10UF 16V	
C202 ,C211	CAPACITOR,CHIP,1000PF 50V	
C203 ,C212	CAPACITOR,CHIP,6800PF 50V	
C204 ,C218	CAPACITOR,CHIP,TANTALUM,0.1UF,35V	
C205 ,C217	CAPACITOR,CHIP,TANTALUM,4.7UF 10V	
C207 ,C209	CAPACITOR,CHIP,TANTALUM,1UF 16V	
C208 ,C220	CAPACITOR,CHIP,0.01UF 50V	
C210	CAPACITOR,CHIP,2200PF 50V	
C213	CAPACITOR,CHIP,220PF 50V	
C214 ,C223	CAPACITOR,CHIP,1000PF 50V	
C215	CAPACITOR,CHIP,0.47UF 16V	
C216 ,C219	CAPACITOR,CHIP,TANTALUM,2.2UF 10V	
C221 ,C229	CAPACITOR,CHIP,0.01UF 50V	
C222	CAPACITOR,CHIP,TANTALUM,1UF 16V	
C224 ,C225	CAPACITOR,CHIP,1000PF 50V	
C226 ,C227	CAPACITOR,CHIP,1000PF 50V	
C228	CAPACITOR,CHIP,TANTALUM,4.7UF 16V	
C230 ,C232	CAPACITOR,CHIP,TANTALUM,4.7UF 10V	
C231	CAPACITOR,CHIP,0.01UF 50V	
C233	CAPACITOR,CHIP,TANTALUM,2.2UF 10V	
C234 ,C237	CAPACITOR,CHIP,TANTALUM,10UF 10V	
C235 ,C240	CAPACITOR,CHIP,1000PF 50V	
C236	CAPACITOR,CHIP,104 X7S	
C239	CAPACITOR,CHIP,0.1UF 25V	
C241 ,C242	CAPACITOR,CHIP,1000PF 50V	
C243 ,C244	CAPACITOR,CHIP,1000PF 50V	
C245 ,C246	CAPACITOR,CHIP,100PF 50V	
C247	CAPACITOR,CHIP,100PF 50V	
C248	CAPACITOR,ELECTROLYTIC,220UF 10V	
D201	DIODE,DAP202KT	
D202	DIODE,DAN202UT	
D204	DIODE,DAN202KT	
IC201	IC,NJM3403AV-CT	
IC202,IC203	IC,TK11250M-CT	
IC204	IC,BA1604F-CT	
IC205	IC,NJM2070M-CT	
N201	WIRE ##	
P201	POST-08-6212-024-CT	
P202	POST-IMSA-9110S-14	
P204	POST-IMSA-9110S-10	
Q201	TRANSISTOR,DTA123JKT	
Q202	2SC4116T-G,L	
Q203	TRANSISTOR,DTC343TKT	
Q204 ,Q205	2SA1298T-O,Y	

**AF CIRCUIT BOARD (35L9720/36C9820)**

<b>LOCATION No.</b>	<b>DESCRIPTION</b>	<b>RMC Part No.</b>
Q206	TRANSISTOR,DTA143EKT	
Q207	TRANSISTOR,DTC124EKT	
R201 ,R227	RESISTOR,CHIP,3.3KOHM 1/16W	
R202	RESISTOR,CHIP,150KOHM 1/16W	
R203 ,R216	RESISTOR,CHIP,6.8KOHM 1/16W	
R204 ,R211	RESISTOR,CHIP,56KOHM 1/16W	
R205 ,R223	RESISTOR,CHIP,47KOHM 1/16W	
R206 ,R215	RESISTOR,CHIP,68KOHM 1/16W	
R207	RESISTOR,CHIP,2.2KOHM 1/16W	
R208 ,R219	RESISTOR,CHIP,10KOHM 1/16W	
R209	RESISTOR,CHIP,5.6KOHM 1/16W	
R210 ,R226	RESISTOR,CHIP,33KOHM 1/16W	
R212	RESISTOR,CHIP,56KOHM 1/16W	
R213 ,R214	RESISTOR,CHIP,39KOHM 1/16W	
R217	RESISTOR,CHIP,8.2KOHM 1/16W	
R218	RVC-RH03AXA-222-CT	
R220	RESISTOR,CHIP,220KOHM 1/16W	
R221 ,R222	RESISTOR,CHIP,4.7KOHM 1/16W	
R224 ,R236	RESISTOR,CHIP,10KOHM 1/16W	
R225	RESISTOR,CHIP,10OHM 1/16W	
R228	RESISTOR,CHIP,33KOHM 1/16W	
R229	RESISTOR,CHIP,4.7KOHM 1/16W	
R230	RESISTOR,CHIP,220OHM 1/16W	
R231	RESISTOR,CHIP,6.8KOHM 1/16W	
R232	RESISTOR,CHIP,56OHM 1/16W	
R235	RESISTOR,CHIP,47KOHM 1/16W	
R237 ,R238	RESISTOR,CHIP,10KOHM 1/16W	
R239	RESISTOR,CHIP,1.00OHM 1/16W	
R240	RESISTOR,CHIP,0OHM 1/16W	
R250	RVC-RVG4M01-103-CT	
SW201	SWITCH SKHHLN	

### VOL CIRCUIT BOARD (35L9730/36C9830)

LOCATION No.	DESCRIPTION	RMC Part No.
N501	QS-CONN-ZHR-09	
VR501	VOLUME (SW)	
VR502	VOLUME	

### SW CIRCUIT BOARD (35L9740/36C9840)

LOCATION No.	DESCRIPTION	RMC Part No.
SW701	SWITCH SKQDPA-CT	

### CPU CIRCUIT BOARD (35L9810/36C9910)

LOCATION No.	DESCRIPTION	RMC Part No.
C400 ,C401	CAPACITOR,CHIP,104 X7S	
C402	CAPACITOR,CHIP,TANTALUM,1UF 16V	
C403 ,C404	CAPACITOR,CHIP,100PF 50V	
C405	CAPACITOR,CHIP,104 X7S	
C406	CAPACITOR,CHIP,TANTALUM,10UF	
C407 ,C408	CAPACITOR,CHIP,22PF 50V	
C409	CAPACITOR,CHIP,1000PF 50V	
F400	CERAMIC FILTER,CSB1200JT	
F401	X'TAL,32.768KHZ	
H400	LCD,210	
IC400	IC-M34520M6-111FP-YT	G263718-13
IC401	IC,RH5VA45AA-CT	
IC402	IC,93LC46X-CT	
N401	STRIP WIRE	
P401	POST-08-6212-024-CT	
PL400,PL401	PILOTLAMP,100-3/4	
Q400	DTB123YKT	G263718-14
Q401	TRANSISTOR,DTC124EKT	
R400 ,R401	RESISTOR,CHIP,4.7KOHM 1/16W	
R402 ,R403	RESISTOR,CHIP,4.7KOHM 1/16W	
R404 ,R406	RESISTOR,CHIP,4.7KOHM 1/16W	
R405	RESISTOR,CHIP,1KOHM 1/16W	
R407 ,R427	RESISTOR,CHIP,10KOHM 1/16W	

---

# SECTION 7

---

## APPENDIX

### 7.1 VHF MARINE CHANNEL USAGE GUIDE AND LICENSING REQUIREMENTS

Most of the information found in this section is reprinted in whole or in part from FCC Information Bulletin No. 2 REVISED EDITION February 1991 and FCC Fact Sheet PR-5000 March 1990.

#### REMEMBER:

- Maintain a radio watch on Channel 16. Channel 16 is used for distress and safety purposes only.
- Use VHF Channel 70 only for Digital Selective Calling (DSC). It may be used for general-purpose calling using DSC. Your cooperation in not using Channel 70 for general intership communications is necessary to prevent interference.
- Your VHF transceiver has a high-low power switch. Use low power whenever feasible. Unnecessary high-power operations can interfere with other important communications.
- Always use your radio call sign at the beginning and end of each transmission.
- Be sure only qualified persons operate your radio. You are responsible for control of your radio. Know the rules.
- Limit calls to other vessels to 30 seconds. If you receive no reply, wait 2 minutes; then try again. Keep communications brief and avoid chit-chat.
- Never transmit false distress messages, and never use profanity on the air.

#### OTHER REMINDERS:

- Do not install or operate your radio until it is licensed. You can obtain a station license and call sign by completing FCC Form 506 and mailing it with the required fee to the FCC, Marine Ship Service, P.O.Box 358275, Pittsburgh, PA 15251-5275. Form 506-A provides you with immediate operating authority, valid for 90 days after you mail your license application.

You need a radio operator license to operate VHF Marine Radio only if you plan to dock in a foreign port or leave a foreign port to dock in a U.S. port.

- Your radio license is not transferable. If you sell your boat, request the FCC to cancel your station license.

If you replace your radio, you do not need to change your license unless the new radio operates on another frequency band. If you install equipment to operate on another frequency band, apply for modification of your license.

- If you carry more than six passengers for hire, your vessel must be certified as a passenger-carrying vessel by the FCC and the Coast Guard.

#### **Licensing Requirements for Hand Held Portable VHF Marine Transceivers 10 Watts Power or Less**

All transceivers, hand helds included, operated in the Maritime Radio Services are required to be operated under and appropriate maritime station license. Operation of hand held VHF Marine transceivers without proper station license can lead to fines and/or administrative sanctions issued against its user and/or owner.

VHF Marine hand held transceivers can be operated and licensed as follows:

- a) **Associated Ship Unit:** A hand held VHF Marine transceiver can be operated under an existing valid ship station license under the following conditions only:
  - i) Except for safety purposes, the hand held transceivers must be used only to communicate with the ship station with which it is associated. Such associated ship units MAY NOT be operated from shore.
  - ii) The transmitting power is limited to ONE WATT only.
  - iii) The hand held transceiver must be identified by the call sign of the ship station along with its associated unit designator.
- b) **Portable Ship Station:** The Commission may grant a station license permitting operation of a portable ship station aboard different vessels of the United States. Each application (FCC Form 506-Application for a Ship Radio Station License) for a portable ship station license must include a showing that:
  - i) The station will be operated aboard a vessel.
  - ii) A station license for portable equipment is necessary to eliminate separate applications to operate a ship station aboard different vessels.
- c) **Marine Utility Station:** A utility station in the maritime mobile service consists of one or more hand held transceiver units licensed under a single authorization. Each unit is capable of operating while being hand carried by an individual. There are two types of stations authorized:
  - i) **Marine Utility Coast** – when transmitters are located on land; may communicate directly to vessels only.
  - ii) **Marine Utility Coast/Ship** – transmitters from land may communicate with vessels or when aboard a vessel, may communicate with other vessels or coast stations.

**NOTE:** A Marine Utility Ship license will not be authorized.

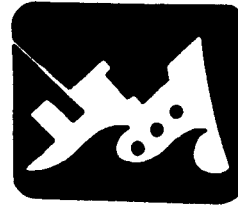

## **Emergency**

### **Channel 16**

If :

- Your ship is sinking, or on fire
- Someone has been lost overboard
- There exists grave and imminent danger

Use this distress procedure:

- Select Channel 16
- Say "Mayday, Mayday, Mayday."
- Give call sign and boat name
- Give location of boat
- Describe emergency
- If no answer, repeat; then try and other channel

Caution:

Every ship at sea is obliged to give absolute priority to radio communications relating to ships in distress – it is vital that false distress calls or messages not be broadcast.

P 204

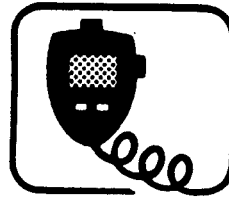

## Calling

### Channel 16 & Working Channel

If – you wish to establish communications with another station

And – you know which working channel the station is monitoring

Then – initiate the call directly on that working channel

If – you wish to establish communications with another station

And – you do not know what working channel the station may be monitoring

Then – initiate the call on channel 16. After contact is made switch to a working channel.

**NOTE: Due to congestion on channel 16 caused by frequent hailing of other vessels, the FCC has approved channel 9 as a second hailing channel.**

Avoid excessive calling and radio checks

Always monitor before transmitting

Never interrupt emergency communications

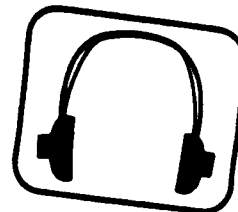

## Monitoring

### Channel 16 & Working Channel

- E** When – your VHF station is turned on and it is not being used to exchange communications
  - C** You Must – monitor channel 16
- As an operating convenience, many stations employ a second receiver so that they can monitor a working channel and channel 16 simultaneously.

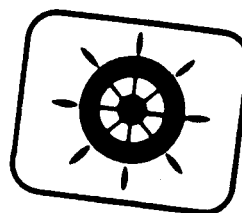

## Intership Safety

- Channel: 6
- Vessels: Any
- Use: Communicating navigational and weather warnings to other ships
- Communicating with U.S. Coast Guard stations or other vessels during search and rescue operations
- Between: Ship-to-ship only
- Comments: Do not use for routine communications. This is a safety channel.



## **U.S. Coast Guard**

Channel: 22

Vessels: Any

Use: Working channel for exchange of communications with stations of the U.S. Coast Guard

Between: Ship to U.S. Coast Guard ship, coast to aircraft stations

Comments: U.S. Coast Guard does not regularly monitor this channel. Establish contact on channel 16 and shift to channel 22 as directed.

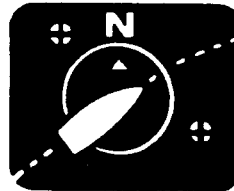

## **Navigation**

Channel: 13

Vessels: Any

Use: Safety communications pertaining to the maneuvering of vessels or the directing of vessel movements

Primarily ship-to-ship and secondarily ship-to-coast

This is commonly called the Bridge-to-Bridge channel. Large vessels and towboats depend on this channel for their safe navigation. Railway or highway bridges which open for ship navigation often operate on this channel.

Bridge-to-Bridge stations must reduce power to one watt for routine operations.

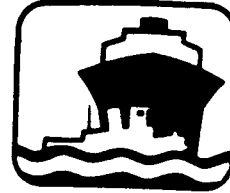

## **Port Operations**

**Channels:** 5, 12, 14, 20, 65, 66, 73, 74, [77]

**Vessels:** Any

**Use:** Messages relating to the operational handling, movement and safety of vessels in or near ports, locks and waterways

**Between:** Ship-to-ship or ship-to-coast

**Comments:** Channel 77 is limited to communications to and from commercial pilots concerning the movement and docking of vessels.

**Note:** Channels 11, 12, 13 and 14 are used for vessel traffic service on the Great Lakes, St. Lawrence Seaway and designated major ports.



### **Non Commercial (Boat Operations)**

Channels: 9, 68, 69, 71, 72, 78

**Vessels:** Recreational boats and any others not used primarily for commercial transport.

**Use:** Communications pertaining to the needs of the vessel (i.e., fishing, rendezvous, maneuvers, berthing, scheduling of repairs, provisioning, etc.)

**Between:** Ship-to-ship or ship to limited coast stations

**Comments:** Channel 72 may not be used for ship to coast communications. Channel 9 is shared with Commercial users.

If you regularly monitor one of these channels with a second receiver, please notify frequently-called stations of this practice. Help reduce congestion on channel 16.



### **Commercial**

Channels: 7, 8, 9, 10, 11, 18, 19, 67, 79, 80, [88]

**Vessels:** Those used primarily for commercial transport of persons or goods, or engaged in servicing other vessels

**Use:** Communications pertaining to the purpose for which the vessel is used

**Between:** Commercial transport vessels (ship-to-ship) or between commercial transport vessels and limited coast stations

Channels 8, 67 and 88 may not be used for ship-to-coast communications

Recreational boats are not permitted to use these channels

Channel 88 not available on Great Lakes and St. Lawrence Seaway.

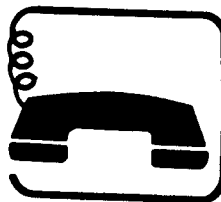

### **Marine Operator**

**Channels:** 24, 25, 26, 27, 28, 84, 85, 86, 87, 88

**Vessels:** Any

**Use:** To place a telephone call to any location in the world or to a vessel outside of your transmitting range

**Between:** Vessels and public coast stations

**Comments:** Contact the marine operator on the channel assigned to your navigating area. If unable to determine this channel, use channel 16.

Be patient. Do not interrupt calls in progress. Avoid excessive calling if the operator does not answer – give the operator a chance to reply.



### **State Control**

**Channel:** 17

**Vessels:** State and local government

**Use:** Coordination, regulation and control of boating activities and the rendering of assistance to vessels.

**Between:** Ship and coast stations associated with state and local governments.

## PHONETIC ALPHABET:

To help make call letters more clearly understood, and to assist in spelling out similar sounding or unfamiliar words, radiotelephone users usually employ the international phonetic alphabet.

### Phonetic alphabet:

A-ALPHA

B-BRAVO

C-CHARLIE

D-DELTA

E-ECHO

F-FOX-TROT

G-GOLF

H-HOTEL

I-INDIA

J-JULIET

K-KILO

L-LIMA

M-MIKE

N-NOVEMBER

O-OSCAR

P-PAPA

Q-QUEBEC

R-ROMEO

S-SIERRA

T-TANGO

U-UNIFORM

V-VICTOR

W-WHISKEY

X-X-RAY

Y-YANKEE

Z-ZULU